

BERRY FLOOR

L a m i n a t e

Installation Manual

Table of Contents

1. PRODUCT	3
2. RECOMMENDED AREAS	3
3. ACCLIMATION	3
4. TOOLS REQUIRED	4
5. THE SUPPORTING FLOOR	4
6. SUBFLOORS MUST BE CHECKED PRIOR TO INSTALLATION	5
7. RADIANT HEAT	5
8. EXPANSION JOINTS	6
9. UNDERLAYMENTS	6
10. LAYOUT AND MEASURING	6
11. SCANNING AND MIXING PLANKS	7
12. CUTTING THE PLANKS	8
13. LAYING INSTRUCTIONS GENERAL (ANGLE-ANGLE)	8
14. LAYING INSTRUCTIONS LOUNGE	12
15. PLANK REMOVAL	16
16. DOOR JAMBS	16
17. INSTALLING STAIRS	17
18. INSTALLATION IN WET AREAS	18
19. MOLDINGS	18
20. MAINTENANCE	19

If you are installing a product not showing here, please call 1-888-929-7994

1. PRODUCTS

The Berry Floor brand products are manufactured with mechanical locking systems under the license of Välinge Innovation Patents. The mechanical locking system allows that the different planks be aligned and joined without using glue or special tools.

Berry Floor laminate features a high density fibreboard core with direct laminated papers, papers impregnated with melamine resin and aluminum oxide. And at the back a counter layer for balance, also paper impregnated with melamine resin.

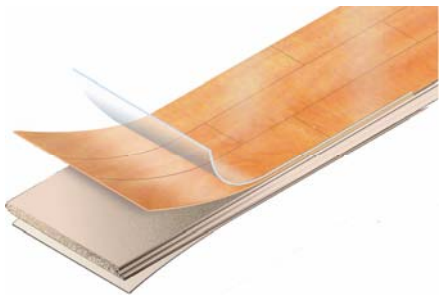

Berry Floor laminate flooring is a DPL or Direct Pressure Laminate, which, because of how it is manufactured, cannot delaminate.

2. RECOMMENDED AREAS

Berry Floor products are recommended for residential areas such as kitchens, living rooms, family rooms, etc. See special instructions for installing over radiant heated floors (see chapter 7). Berry Floor products can be used in light commercial areas and are suitable for light commercial use. Recommended applications include most normal dry commercial applications such as hair salons, dentist offices, and professional office applications.

Berry Floor products are not recommended for installations in rooms with in-floor drainage, commercial kitchens or other similar areas.

3. ACCLIMATION

Acclimation is a highly recommended procedure prior to installation of Berry Floor either on the “job site” or in “like job site conditions” location, as this will make the installation easier and remove concerns of over expansion or under contraction of the flooring. To accomplish this, cross stack the UNOPENED BOXES approximately 8” apart to create air flow in the room where the floor is to be installed for at least 48 hours prior to installation. Do not stack boxes next to an outside wall. Do not open Berry Floor cartons until they are to be installed. Heating/air conditioning must be on and set between 60 to 80 degrees and relative humidity in the room should be 40% to 60%.

4. TOOLS REQUIRED

- Safety glasses and dust mask (follow NIOSH recommendations)
- Measuring tape and square
- Table type power saw with dust collector, circular saw with (40 to 60 tooth) carbide tipped blade (thin kerf) or a power jigsaw or handsaw
- Handsaw or door jamb saw for door jambs
- Spacer blocks or plastic or wood ¼ inch thick minimum
- Pull bar, hammer and tapping block (tapping block should NOT be used for general installation, only to be used for sideslipping a board under a door jamb; pull bar may be used to pull in the last row)

5. THE SUPPORTING FLOOR

Berry Floor laminate flooring can be installed on most existing floors, wooden, PVC and concrete floors. All carpeting and padding needs to be removed. Make sure that the surface is clean, dry, and flat (3/16" over a 10' span) with gradual changes not sharp or abrupt changes. Supporting floors must be rigid as too much deflection can result in a failed installation.

5.1 Wooden subfloors

Wooden and wood based materials (plywood, OSB, particle board) must be dry, with a moisture reading between 6-12% (this must be checked with a moisture meter such as a Mini Lignomat). Wooden subfloors must not have a moisture reading greater than 12%.

Ensure that the boards of the subfloor are properly nailed, glued or screwed to the supporting beams and that you do not have any squeaking or depressed areas. Patch if needed and fill depressed areas with floor leveling compounds. Raised areas must be sanded down. The subfloor must be level and flat to within 3/16" over a 10' span. Floor joists cannot be spaced greater than 16" apart. Wooden subfloors over crawl spaces, pier and beam and manufactured housing : open all vents in the crawlspace to ensure proper air circulation. Always install a moisture inhibiting membrane under the Berry Floor laminate floor.

5.2 Concrete subfloor

All types of concrete floors, light concrete floors or ceramics demand a moisture inhibiting membrane. Vinyl over concrete does not constitute a moisture inhibiting membrane. Use a

polyethylene film of 6-8 mil. This moisture inhibiting membrane must be applied with a minimum of 8 inch overlap, and taped with a waterproof tape and turned about 2" up the wall. This membrane is to be covered if you will be using wooden wallbases. If you use a rubber wallbase then the membrane is to be clean cut once the floor is installed. You also need an underlay material with a thickness of min 1/8 inch.

Concrete subfloors must be at least one month old prior to installation, and tested by one of the following. Gypcrete subfloors must be at least one month old prior to installation, and tested by one of the following. (see below) However Gypcrete is a thin layer light weight concrete and will not need an additional polyethylene film if the underlayment used has a moisture barrier attached to it.

Moisture testing for concrete and light concrete (gypcrete) floors.

- 1) Calcium chloride test of 5 lbs/24hrs./1000 sq.ft.
- 2) 4% on the Tramex Concrete Moisture Encounter CME4

No "Mat Testing" – not recommended as too unreliable.

5.3 Moisture inhibiting membranes

Must be 6-8 mil. Polyethylene film used with a waterproof tape at the seams and must run up the wall the height of the trim (approx. 2").

Moisture barriers can be already attached to underlayments, however, they must be sufficient enough to qualify as a moisture barrier. Check with manufacturer specs.

If it is too difficult to run the moisture barrier used up and behind the molding, then run the moisture barrier to the wall and attach a high quality duct tape to the moisture barrier, then run the duct tape behind the molding.

6. SUBFLOORS MUST BE CHECKED PRIOR TO INSTALLATION

Berry Floor laminate flooring is to be installed as a floating floor, which means the boards are not be glued together or tacked to the underlay. Leave an expansion gap around the perimeter of the room (see table chapter 8). Remove base moldings. If necessary, the boards in the first row can be cut to smaller size on their width. Before installation, clean – sweep or vacuum also the subfloor so that it is free of dirt and debris. Check also the moisture in the subfloor by using a moisture meter (6% - 12%). Be sure the moldings you are replacing will sufficiently cover the expansion space (see chapter 8).

The subfloor must be flat. Deviations in the subfloor have to be levelled to within 3/16” over a 10’ area by either filling or sanding.

7. RADIANT HEAT

In order to achieve the best installation result when combining Berry Floor laminate flooring with heated subfloors, we want you to consider the following : Radiant heat systems must be operating for a minimum of 3 weeks prior to the installation of the Berry Floor laminate floor. The system should be turned off at the time of the installation, or, if in winter, should be set at exactly 65 degrees Fahrenheit for a minimum of 48 hours prior to installation. After the installation is complete, or when turning

on the radiant heat system from a cold start, the operating temperature may be increased by a maximum of 5 degrees Fahrenheit in a 24-hour period. The maximum allowable surface temperature for laminate floors is 80 degrees Fahrenheit. Berry Floor laminate floors are not suitable for installation over radiant heating systems that otherwise expose the floor to wide variations in temperature, such as hotwire induction mat systems.

The subfloor must be flat. Deviations in the subfloor have to be levelled to within 3/16” over a 10’ area by either filling or sanding.

The installation area of Berry Floor laminate flooring shall not contain heated and non-heated areas, unless expansion joints separate them. Start by placing a 6-8 mil polyethylene film with waterproof tape at the seams. This moisture inhibiting membrane must be applied with a minimum of 8 inch overlap, and taped with a waterproof tape and turned about 2” up the wall. This membrane is to be covered if you will be using wooden wallbases. If you use a rubber wallbase then the membrane is to be clean cut once the floor is installed. You also need an underlay material with a thickness of min 1/8 inch.

Keep in mind that loose rugs or carpets may accidentally function as heat insulators and raise the temperature to more than the tolerated maximum surface temperature of 80 degrees Fahrenheit (28° C).

8. EXPANSION JOINTS

Berry Floor brand products (with the exception of **Casa, Lounge, Château and Mansion**) may be installed in a single room not to exceed 50 linear feet x 32 linear ft. (or 1600 square feet). T-moldings are recommended when going through doorways or narrow openings. In cases where T-moldings are not desirable, perimeter expansion spacing must be observed.

Expansion Table (not to exceed 32' x 50' or 1600 sq. ft.)

Length (ft)	Width perimeter (inch)
20	1/4
30	3/8
40	1/2
50	5/8

IMPORTANT : Casa, Lounge, Château and Mansion are the exception, and are not to exceed 32 linear ft. in either direction or 1024 sq.ft. with an expansion gap of 3/8" in.

Note: basic transitions may not completely cover expansion spaces.

9. UNDERLAYMENTS

It is essential to use an underlayment. Underlayments will allow the floor to "float" as it expands and contracts. They also offer sound absorption and compensate for small surface irregularities. An underlayment should never exceed 1/8" in thickness. Underlayment and moisture inhibiting membranes are two separate items and should not be confused. Not all underlayments have an attached moisture inhibiting membrane. Therefore, if the installation requires it, a 6-8 mil moisture inhibiting membrane should be used (see chapter 5).

10. LAYOUT AND MEASURING

Determine which way to run the planks (rules of thumb):

1. Lengthwise in the longest direction of the room
2. Lengthwise perpendicular to the main source of incoming light.
3. To avoid straddling a door jamb with a plank, use a T-molding or measure back to the starting wall to ensure a plank connection within the door jamb area. It is recommended that you will not end up with a narrow strip at the end that is less than 2 inches wide on any wall in the room. It is recommended to cut the first and last rows so they are equal in width. When installing Berry Floor tiles, it is also best to position the starting board cut so that the tile pattern matches on both sides of the room. Be certain you are aware of any walls in the room that are not square. A wall that is out of square may affect pattern layout. If remodeling, remove existing base and quarter round moldings carefully so they can be reused after the floor has been installed. Undercut all door jambs so that the Berry flooring will easily slide underneath them. Using a scrap piece of Berry Floor laminate and underlayment as a guide, undercut the jambs with a jamb saw or regular handsaw. All Berry Floor laminate flooring are floating products, meaning they are not fastened to the subfloor or any other fixed objects. Restricting the floor from floating will prevent it from properly expanding and contracting due to changes in temperature and humidity. Always leave an expansion space between the Berry

Floor laminate and all walls or other fixed objects.

4. Pinch points where the use of T-moldings is recommended (see picture below).

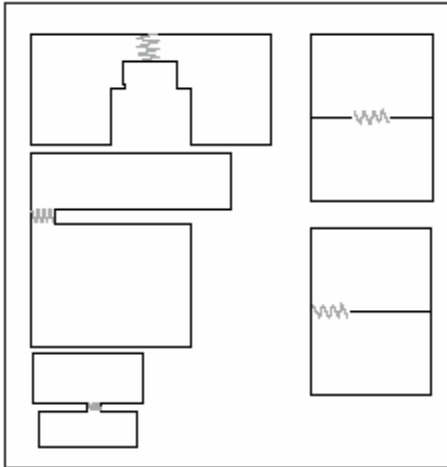

NOTE :

Divided rooms can often have different environments, as some may have a wood stove at one side (dry heat) and a kitchen on the other side (high humidity).

11. SCANNING AND MIXING PLANKS

NOTICE TO INSTALLER :

Planks showing visible surface defects should never be installed. These boards should be put aside and a product claim should be raised against them. Labor claims resulting from the installation of such boards will not be honored.

For best results it is recommended that material be mixed from three or four boxes when installing Berry Floor laminate flooring. Do not put like planks next to each other. Each plank of Berry Floor Tiles has a design with multiple tiles. To achieve the most natural looking floor with Berry Floor Tiles, you should mix planks out of multiple boxes

(four or five) as you install. If grout lines on the end of the planks vary in width, place wide grout lines next to planks with narrow grout lines, this will maintain a constant grout line from row to row.

12. CUTTING THE PLANKS

When cutting Berry Floor laminate flooring with a circular saw, it is recommended to cut with the decorative side facing down. When using a table type power saw (40-62 carbide blade), or power jig saw, or handsaw, cut with the decorative side up.

- Remember that dust will be created when sawing wood products. Airborne wood dust can be an explosive hazard and an irritant to eyes, skin and the respiratory system. Wood dust has been classified by the International Agency for Research in Cancer as a carcinogen. It is therefore important to use dust collectors on power tools. Wear appropriate clothing and an approved dust mask.
- Remember to always start a row with a plank at least 12” long to insure the minimum end joint offset is established.

13. LAYING INSTRUCTIONS GENERAL (ANGLE – ANGLE)

13.1 Getting started

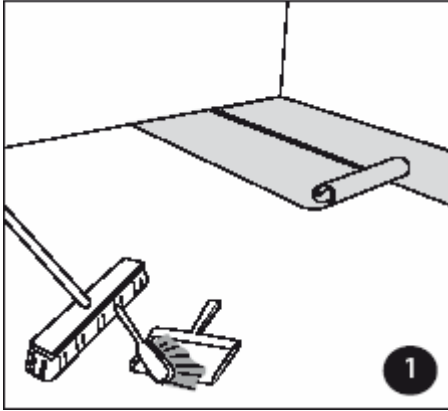

Check the laminate floor boards before you start to make sure that they are not in any way damaged or have quality defects. Clean the subfloor and, if necessary, lay down a moisture inhibiting membrane. Install your underlayment/pad.

13.2 First row

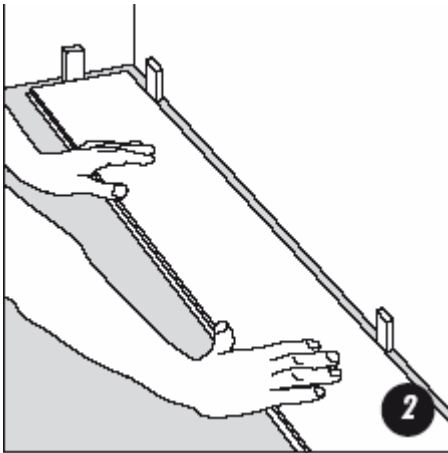

Start the installation of the boards in the left-hand corner, with the tongue-side against the wall. Make sure you are placing the short side of the board $\frac{1}{4}$ inch minimum from the wall (refer to the expansion perimeter gap table). The long side distance can be pushed into place

when three rows have been installed $\frac{1}{4}$ " in. minimum (see table). If the wall is uneven, the floorboards must be adapted to its contours. Remove the first row. Cut the floorboards as required and complete the first row.

13.3 End section

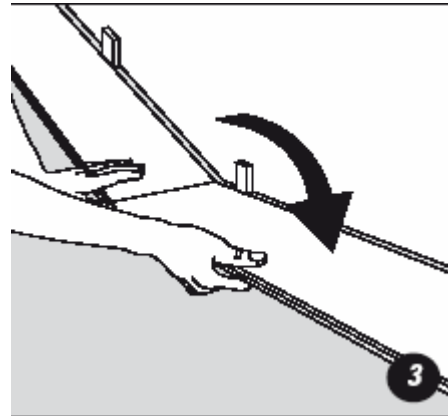

Angle the end joint of the next board into the first board already on the floor, then lay the second board down to the floor. Complete the whole first row in this same manner.

13.4 Place the final floorboard

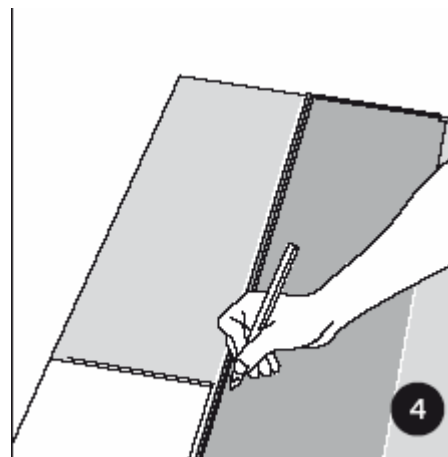

Place the final board face down and the short side without the locking strip towards the wall. Allow for sufficient expansion space when cutting the board to the size required (see table in chapter

8). Mark where the floorboard is to be cut.

13.5 Cutting the boards

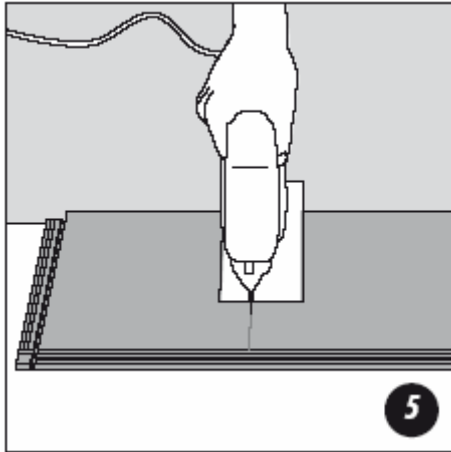

Place the board face up on the work surface and cut to size using a jigsaw. If you use a table or a circular saw, then use a thin kerf blade 40-60 tooth.

13.6 Starting the second row BOARD BY BOARD PROCEDURE (please see below for alternative full-row installation instructions)

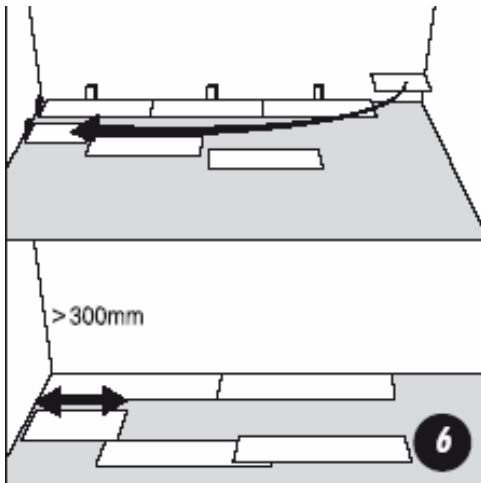

Use a cut piece of board from the previous row to start the next row. This

must be at least 12 inches long. If this piece is too short start with a new board cut in half. Always ensure that the end joints are staggered at least 12 inches.

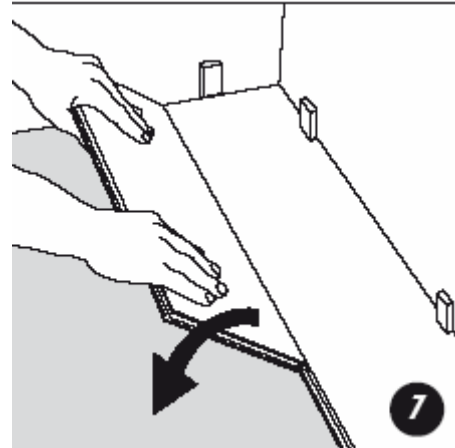

13.7. Continue laying the floor

Place the floorboard at an angle against the floorboard in the previous row, press forward and fold down at the same time, but not yet all the way flat against the floor. The board will now be resting at a slight angle off the floor. Now it is in position for the next board to be joined to it.

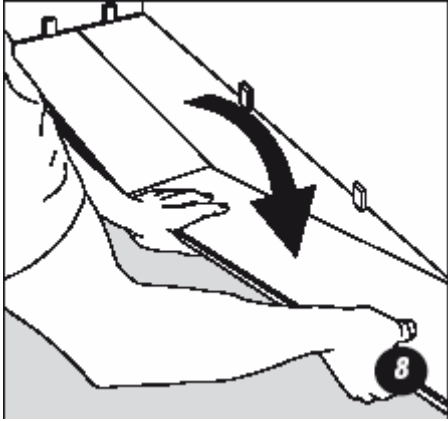

Place the short end of the floorboard at an angle against the previously installed floorboard and fold down. Ensure that the board is positioned on the lower extended groove of the board in the previous row.

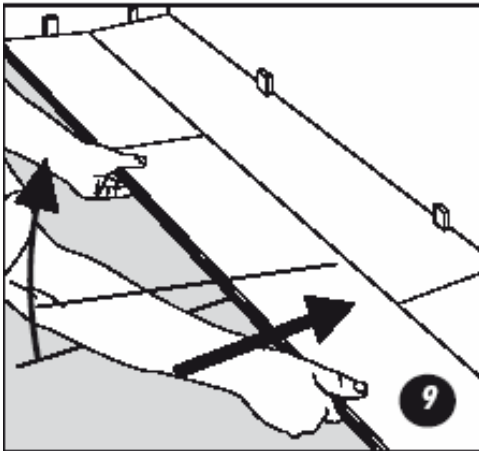

Lift the floorboard up

Lift the board up (together with the board that was previously laid down in the same row). Bring the board down again as soon as the boards are positioned tightly together. Strike the board with the palm of your hand at the end joint to fully engage the lock along the long side of the plank. Now both boards will sit up at a slight angle. Do not pat the boards fully down. After all boards in the row have been similarly put in place, pat the boards down until

they lay flat against the subfloor before starting on the next row.

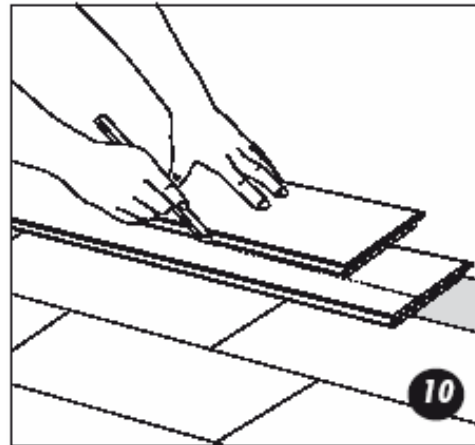

Lay the last row

Measure and cut the board. Leave 1/4" – 5/8" (see table) to the wall.

FULL ROW PROCEDURE (alternate method)

Cut board to ensure 12" stagger. Lay first board of second row down flat on the floor, with lock laying on top of first row's lower extended groove. Engage end joints of all boards in entire second row.

Once the second row has been completely laid down as described above, lift the last board laid down at a slight angle until board slips into the lock. Work your way back down the row, lifting the boards slightly as they slip into the lock. The entire row will be at a slight angle. Now pat down the entire row flat against the floor.

13.8 Holes for pipes

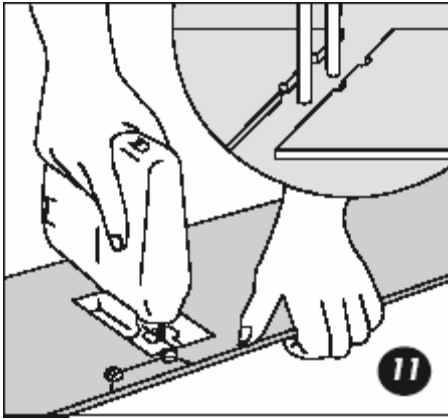

Measure the diameter of the pipe and drill a hole that is 3/8" larger. Saw off a piece as shown in the figure and lay the board in place on the floor. Then lay the sawed-off piece in place.

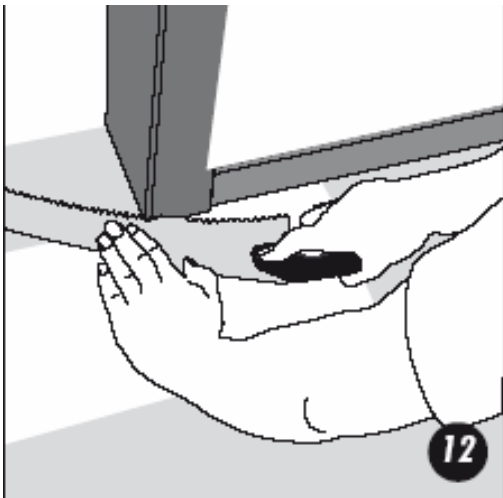

13.9 Door moldings and skirtings

Lay a board (with the decorative side down) next to the door molding and saw as shown in the figure. Then slide the floorboard under the molding.

14. LAYING INSTRUCTIONS LOUNGE

14.1 Getting started

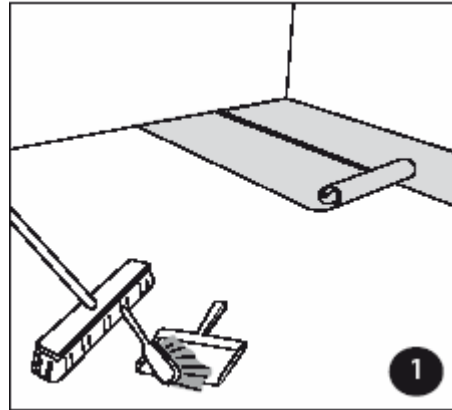

Check the Berry Floor boards before you start to make sure that they are not in any way damaged or have quality defects. After cleaning the subfloor you can roll over the plastic foil and underlay material. The plastic foil has to overlap a minimum of 8 inches.

14.2 First row

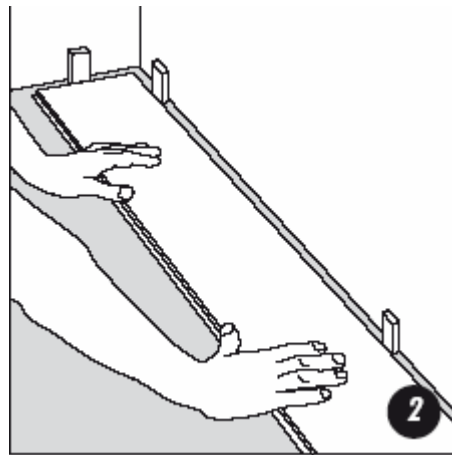

Start installation of the boards in the left hand corner, tongue-side against the wall. Make sure you are placing the short side of the board 1/4-3/8 inch from the wall. The long side distance can be pushed into place when three rows have been installed (mind distance of 1/4-3/8 inch). If the wall is uneven, the floorboards

must be adapted to its contours. Remove the first row. Cut the floorboards as required and then relay them by sliding them in at an angle under the floorboards that are already in position.

14.3 Place the final floorboard

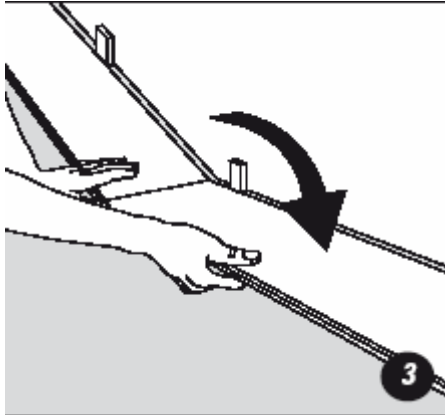

Place the final floorboard face down and the short side without the locking strip towards the wall. The distance to the wall must be $\frac{1}{4}$ - $\frac{3}{8}$ inch. Mark where the floorboard is to be cut.

14.4 Cutting the floorboards

Place the floorboard face down on the work surface and cut to size using a jigsaw. Use a fine-toothed type if you are using a hand saw. In this case cut the floorboards face up.

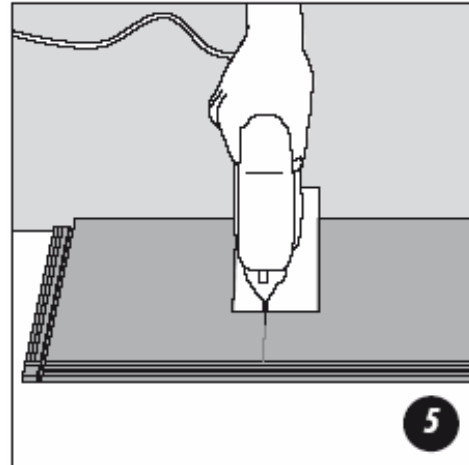
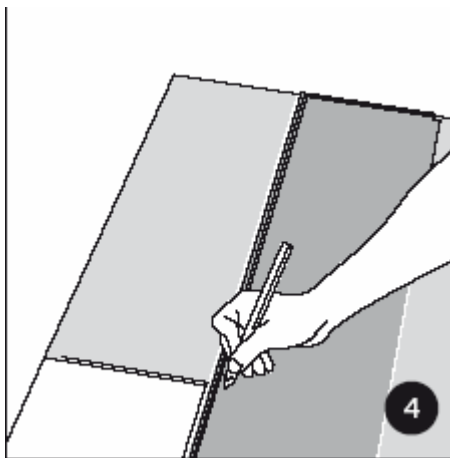

14.5 Starting the second row

Use a cut piece of board from the previous row to start the next row. This must be at least 12 inch long. If this piece is too short, start with a new board cut in half. Always ensure that the end joints are staggered at least 12 inch.

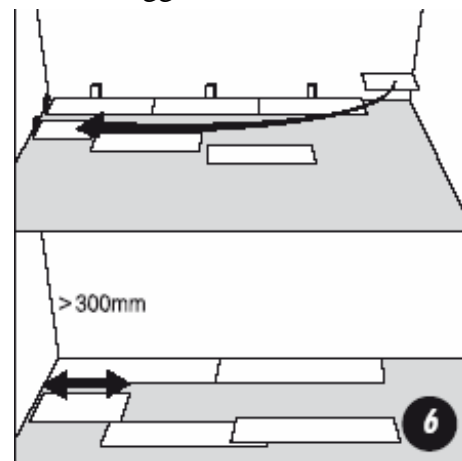

14.6 Continue laying the floor

Place the floorboard at an angle against the floorboard in the previous row, press forward and fold down at the same time.

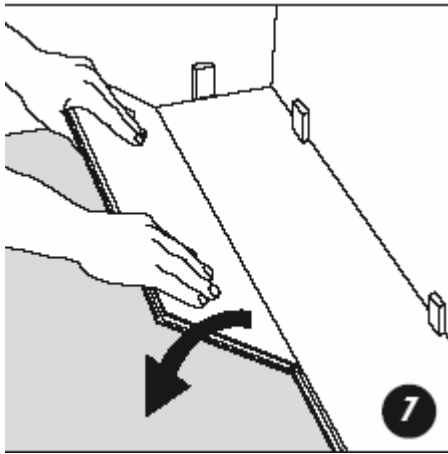

14.7 Take a new board

Take a new board A (please refer to the drawing below for references to A and B) and push it at an angle into the lock of the boards already in place on the floor. Push board A down properly so that it joins with side of board B already in place. For the other pieces you should do the same, put in the long side and push it down so that the two short sides are locked in together (= droplock system).

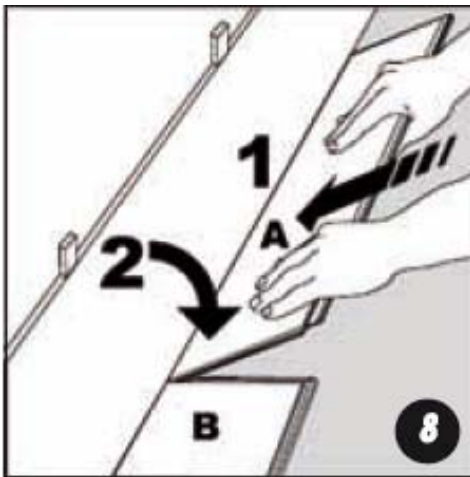

14.8 Laying the last row

To lay the last row, measure and cut the board. Leave $\frac{1}{4}$ - $\frac{3}{8}$ inch to the wall.

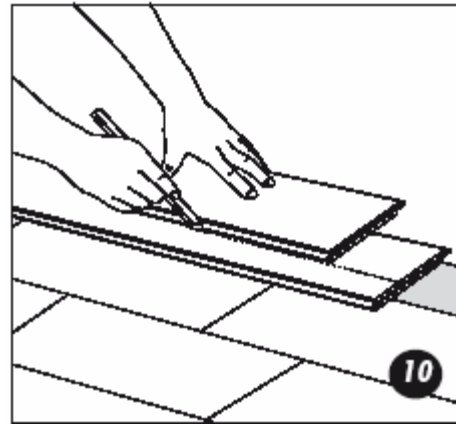

14.9 Holes for pipes

Measure the diameter of the pipe and drill a hole that is $\frac{3}{8}$ inch larger. Saw off a piece as shown in the figure and lay the board in place on the floor. Then lay the sawed-off piece in place.

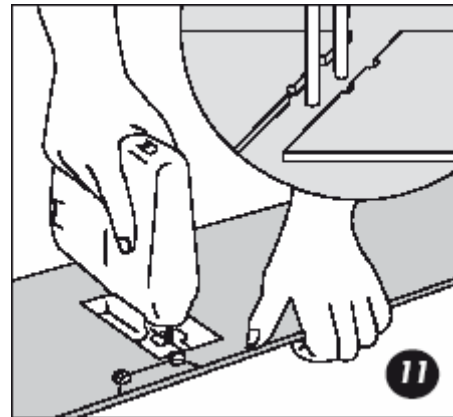

14.10 Door molding and skirtings

Lay a board (with the decorative side down) next to the door molding and saw as shown in the figure. Then slide the floorboard under the molding.

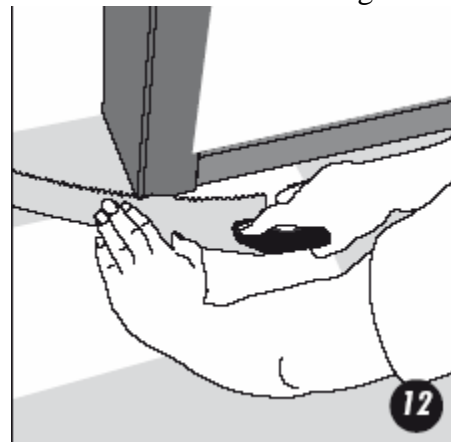

15. PLANK REMOVAL

After installation, should you discover an error in the installation or a damaged plank, you can easily take up the floor and remove the plank. After carefully removing the moldings, place your left hand under the planks and **before** you lift, use your right hand to **pat down firmly** at the joint at the same time you lift the plank you have your left hand under, unfold the planks in reverse order of the installation. Start with the long side and lift the pieces out of the locking joint before unlocking the short joints. Place removed planks flat on the floor. It is a good idea to number the pieces as they are taken up, as the cut pieces are unique to that row. Place the affected material, reinstall the unaffected planks and reattach the moldings.

NOTE : For “PLANK REPLACEMENT” procedure, contact Berry Floor

16. DOOR JAMBS

Always undercut door jambs made of wood. When door jambs are metal and it is not possible to undercut them you must still leave a min. 3/8” spacing (see

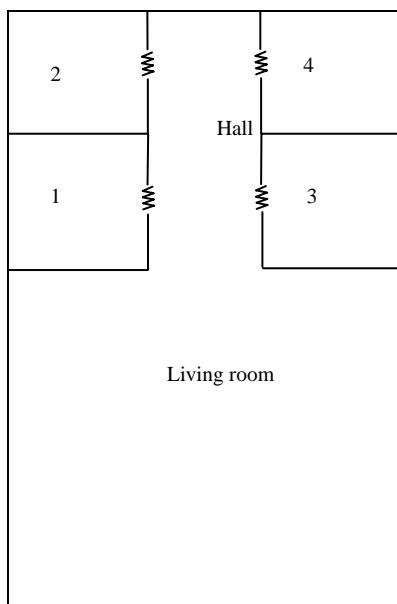

table chapter 8). When around a metal door jamb you cannot undercut use foam rope weather-stripping and 100% silicone over the top or a colored siliconized acrylic latex caulk to fill the gap.

- **Continuous floor method**

When using Berry Floor products, it is not always possible to lift the planks so that they can be angled in for installation in a doorway. In this situation, it is necessary to remove the top of the locking mechanism with a sharp chisel or a small wood plane, and to use an appropriate wood glue (such as a professional wood glue) to hold the planks together. Be careful not to join large rooms together with small doorways as this can put too much stress on the doorway connection.

- **Transition method**

This is the ideal method for installing Berry flooring which is going to extend to other rooms by using a T-molding at the doorways. This method allows for Berry Floor to butt up against any other floor covering material (including Berry Floor) by the use of various transition pieces offered.

17. INSTALLING LAMINATE ON STAIRS

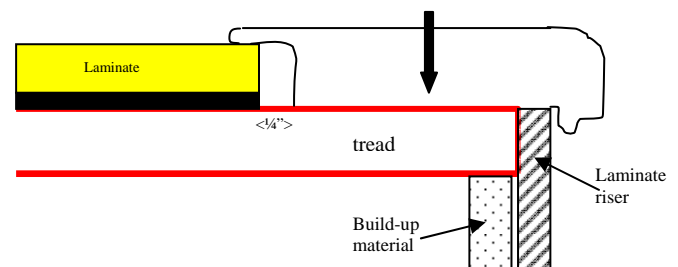

17.1 How to proceed from the top floor to the first step of the staircase down the stairs

It is very important to leave sufficient expansion room for the floor in order to avoid that the stepnose is pushed away by it. We advise to leave ¼” of free space. The stepnose needs to be firmly attached to the floor using screws (on wood with nails and liquid nail) (every 12 inches) (pre-drill the holes, refill the opening).

17.2 Construction of the step

a) The horizontal part (tread)

The expansion space for the horizontal part is minimal given the width of the step (1/16 inch is sufficient). The stepnose will again be fixated with screws (or with nails if we have wooden steps). In order to avoid the horizontal part from moving, it also has to be fixated (nails, screws)

b) The vertical part (riser)

The vertical part stands on the horizontal part, and is fixated using construction-grade adhesive.

When installing laminate on a staircase, neither underlayment nor expansion gaps are required.

It is essential for the stepnose to be tightly secured.

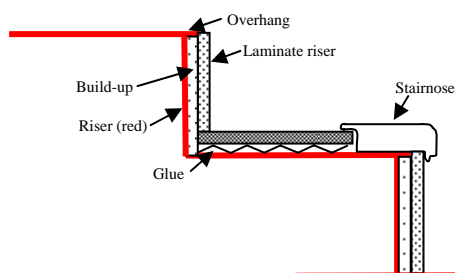

18. INSTALLATION IN WET AREAS

The expansion spaces in all potentially wet areas (in front of dishwasher, behind the refrigerator, behind the washing machine, at outside entries, around the toilet, shower, etc.) must be sealed. Fill the ¼ “ expansion space with weather stripping rope, before applying 100% silicone sealant. In front of the tub you can use a high quality colored siliconized acrylic latex sealant without the weather stripping rope.

Remember that the reason caulking joints can fail is because they have not been cleaned.

- Bathroom floor installations need to have a glue (professional wood glue) or clic seal applied to the joints
- T-moldings are always to be used at bathroom doors and laundry room doors as the sealant that is applied around these areas restricts their ability to move with connecting rooms.

Laundry rooms are also considered wet areas.

19. MOLDINGS

Note : Do not use extreme pressure on moldings against the floor so as to not bind the flooring.

All Berry Floor moldings are laminate wrapped. They are designed to blend with their assigned patterns and should never be attached directly to the Berry Flooring. The following moldings are available for use with Berry Floor :

- Quarter round – nicely frames all flooring projects and covers expansion gaps next to walls.
- Stair nose – a durable rim for the treads and risers on stairways
- Flush Mount Stair Nose – creates a flat, non-trip connection
- T-molding * – bridges the expansion gap between two level surfaces
- Square nose * – used as a transition from laminate flooring to carpet, sliding glass doors, areas around fireplaces, etc.
 - * These molding items are secured to the subfloor using the Monotrack system, which eliminates face nailing
- Reducer * - bridges the gap between two uneven surfaces creating a smooth transition from laminate flooring to wood, ceramic tile or vinyl.
- Wall Base – borders the floor for a finished look and covers expansion gaps next to the walls.
- These molding items are secured to the subfloor using the Monotrack system, which eliminates face nailing.

Attach the plastic Monotrack to the subfloor with either nails, screws or construction adhesive. Make sure that the Monotrack is properly positioned using a scrap piece of the molding to be installed. After securing the Monotrack to the subfloor, simply cut the molding to fit and gently tap into place. The bottom of either the T-molding, square nose or reducer will fit onto the Monotrack for a secure hold. When installing the wall base and quarter round, be sure to cover 1/4" expansion space. All moldings should be attached to the walls and not to the laminate floor.

- Use a power saw with a carbide tip blade to cut laminate wrapped molding.
- Always position the blade to cut down through the laminate surface.
- Measure twice and cut once
- Wear proper eye protection

20. MAINTENANCE

Clean the floor regularly with a vacuum cleaner or dry mop. If necessary, the floor may be cleaned with a laminate floor cleaner in a spray bottle by misting the floor with the cleaner immediately followed by a dry cloth (example : terry cloth type).

Do not use cleaning products that apply a direct spray solution (Swiffer).

To protect the floor we recommend felt pads be placed under chairs and table legs as well as couches or other types of furniture that you may want to periodically move. Metal casters should not be used directly on laminate floors. Plastic casters may leave marks on the floor.

Food and water dishes for animals should have a plastic or vinyl place mat under them. Stains caused by normal use, streaks from shoe-soles, crayons and other dirt can be removed as shown in the following table.

Stain : rubber smears, shoe heel scuffs, dirt from the street, colored pencil, oil crayon –

To remove ... dry brushing, eg. with white nylon pad.

Stain : fruit, berries, milk, beer, wine, tea, lemonade ...

To remove ... wipe off immediately with absorbent cloth; or suitable laminate cleaner if dried on and dry wipe afterwards.

Stain : urine, blood....

To remove ... wipe off immediately with damp cloth, or dry brushing with white nylon pad if dried on; wipe off any clinging residue with suitable laminate cleaner, dry-wipe afterwards.

Stain : nail polish, shoe cream, varnish, lubricating oil, tar, felt-tip pen, ink, mascara, lipstick, carbon paper, typewriter ribbon ...

To remove ... wipe off with cloth soaked in solvent, eg. Acetone, concentrated vinegar, nail polish remover, universal thinners – use sparingly in each case with very little solvent and only in the area of the stain :
Observe safety regulations !

Stain : chocolate, film of fat/grease, cooking oil...

To remove ... suitable laminate floor cleanings product.

IMPORTANT NOTE

The use of steam cleaners is to be avoided at all times.